

## IGBT Chargers Explained

Nasser Kutkut, Ph.D. - PowerDesigners, LLC - Madison, WI

### Introduction

IGBT based chargers have recently emerged in the material handling market place offering a potential replacement to SCR and ferro-resonant counter parts in opportunity and fast charge applications. Unlike SCR and ferro-resonant chargers, IGBT chargers can switch at higher frequencies (kilo-hertz range) and provide better regulation of output voltage and current.

Since all charging equipment need to be isolated from the AC line, transformer isolation is also be required in IGBT based chargers. Transformer isolation provides the required safety isolation from input to output as well as steps down the incoming AC line. Given the type of isolation employed, IGBT chargers are classified as:

- Low frequency (60Hz) isolated chargers
- High frequency (off-line) isolated chargers

### Low Frequency (60Hz) Isolated IGBT Chargers

An IGBT charger with low frequency 60Hz isolation consists of three stages (Fig. 1), namely:

- 1- A input 60Hz isolation transformer
- 2- A diode bridge rectifier
- 3- A step-down “buck” converter consisting of a single IGBT and diode as well as an output filter

Taking a closer look at an IGBT charger with 60Hz transformer isolation (Figure 1) and comparing that with an SCR charger (Fig. 2), one can easily identify the similarities / differences:

- The input 60Hz transformer is the same
- The SCRs are replaced with diodes
- A single IGBT and diode are added
- An output DC choke is added for filtering. Note some SCR chargers also incorporate an output DC choke for reduced AC output ripple.

The IGBT / Diode combination constitute what is referred to as a **step-down (buck)** converter. A buck converter steps down the rectified DC voltage to a level compatible with the battery voltage to be charged.

Although the buck converter technology may seem new to the battery charger industry, the “buck” type converter technology is part of what is called the “**switch-mode**” **power conversion technology** which was **developed in the mid to late 1970s**. In fact, the buck type converter is the simplest power converter topology and is first thing that a power engineering student learns at an introductory power electronics class. The IGBT itself was **developed in the late 1970s to early 1980s** and became a widespread device used in high power motor drives and power supplies by early to mid 1990s.

From a cost point of view, the cost differential of an IGBT charger as compared to an SCR charger is not that high, namely:

- The transformer cost should be the same or even lower for the same power level
- There is almost no cost in replacing the SCRs with diodes
- The only additional cost is that of the added IGBT and diode as well as some cost associated with the output filter.
- The controls associated with a buck converter is very simple and many single chip ICs are readily available from a number of suppliers.

Although an IGBT based charger can provide better regulation of output voltage and current compared with an SCR charger, the use of a 60Hz isolation transformer greatly diminishes many of the potential benefits. The size, weight, and inefficiency of the 60Hz transformer are not that different than an SCR unit. Although there have been claims that an input 60Hz transformer provides additional protection against AC line transients, the reality is otherwise. Protection devices and other design considerations need to be incorporated to make these chargers reliable in industrial applications.

### High Frequency Isolated (Off-Line) IGBT Chargers

The other type of IGBT battery chargers incorporate high frequency isolation transformers as shown in Fig. 3. In this case, the isolation transformer is moved to the high frequency switching stage instead of the being at the input side. The main reasons for that are:

- 1- The size and weight of the transformer is **inversely proportional to the switching frequency**. As such, **a high frequency transformer operating at 60kHz will be 1000 times smaller and lighter than a 60Hz transformer**. This is in fact why the whole power supply industry has opted for high frequency isolation.
- 2- The efficiency of high frequency transformers is very high and approaches 99% or higher in many designs contributing to more efficient power units and lower energy costs.

A high frequency IGBT based charger has better output voltage and current regulation and much faster response to output and input variations.

Some may contend that the removal of the input 60Hz transformer may adversely impact the reliability of the IGBTs. This is far from the truth as the input 60Hz transformer provides no protection against line transients and excessive voltage sags and surges. Shielded transformers may provide protection against electrical noise that may interfere with data and communication systems. The same function can be achieved by utilizing EMI filters, which are far more superior than shielded transformers. In either case, power protection devices, such as transient voltage suppressors (TVS) are needed to provide the needed protection against all sorts of AC transients. In reality, the fast response of a high frequency charger allows it to capture all input transients and adjust operation very rapidly.

For all of the above, PowerDesigners' opted for high frequency isolation. The PowerCharge line of fast and high frequency battery chargers utilize **high frequency isolation** yielding **very high efficiencies and very compact designs**. The weight of the PowerDesigners' high frequency charger **is more than 50% lower than any competitive fast charger** in the market place.

### A Historical Note

The 60Hz transformer isolated switch-mode power supplies **were abandoned by Digital Equipment Corp. in the mid 1970's** in search of better performance and lighter units. Digital equipment settled for high frequency isolated power supplies instead. During the 1970's, Digital Equipment was the largest manufacturer of computer equipment in the world and built millions of mini and mainframe computers with legendary reliability using high frequency isolated switch-mode power supplies. In all of these power supplies, the power switches were directly connected to the AC line and their performance was never marginalized.

The many millions of PC computers in service today use the same high frequency switch-mode technology with high frequency isolation. The many millions of motor drives in use today use IGBTs directly connected to the AC line with no 60Hz transformer isolation. The legendary performance of these power supplies and motor drives is the biggest proof of their reliability and suitability for all applications.

### Conclusion

In summary, high frequency battery chargers employing high frequency isolation are far superior to their low frequency counter parts. When it comes to efficiency, output regulation, size and weight, there is no comparison. This is evident through the widespread use of high frequency isolated power supplies and their unquestioned reliability.

### References:

- [1] R.P. Severns, High Frequency Switching Regulator Techniques, IEEE Power Electronics Specialists Conference (PESC) record, **June 1978**.
- [2] R.D. Middlebrook and S. Cuk, *Advances in Switched-Mode Power Conversion*, Vol. I & II, TESLAcO, **1981**.
- [3] J.B. Baliga, "Field Effect Bipolar Transistor", US Patent 4,331,969, **1982**. (One of the first IGBT patents).
- [4] Can shielded isolation transformers provide power conditioning?  
[http://enews.primediabusiness.com/enews/powerquality/power\\_quality\\_news\\_beat/current](http://enews.primediabusiness.com/enews/powerquality/power_quality_news_beat/current)

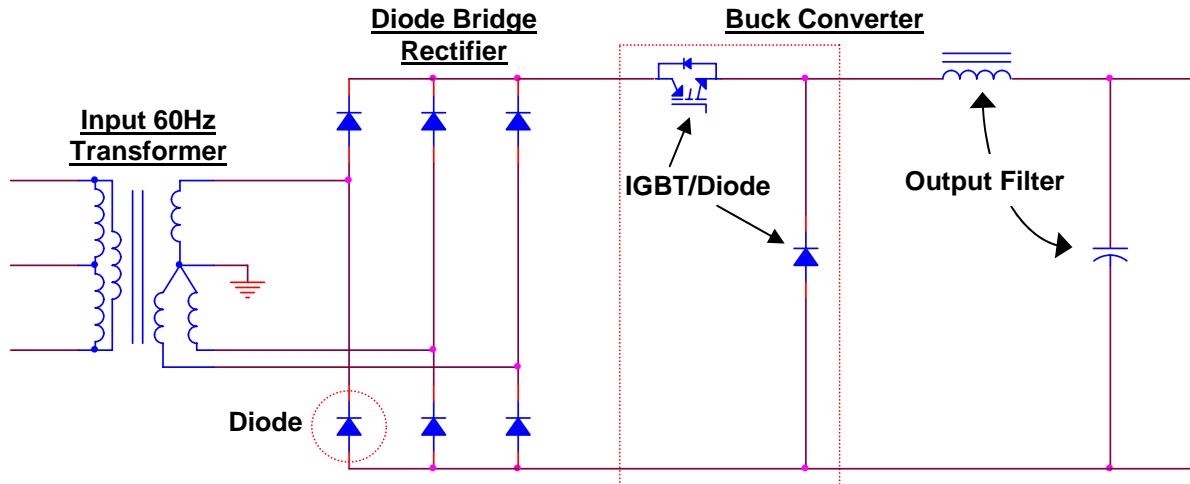

**Fig. 1: Low Frequency (60Hz) Isolated IGBT Charger**

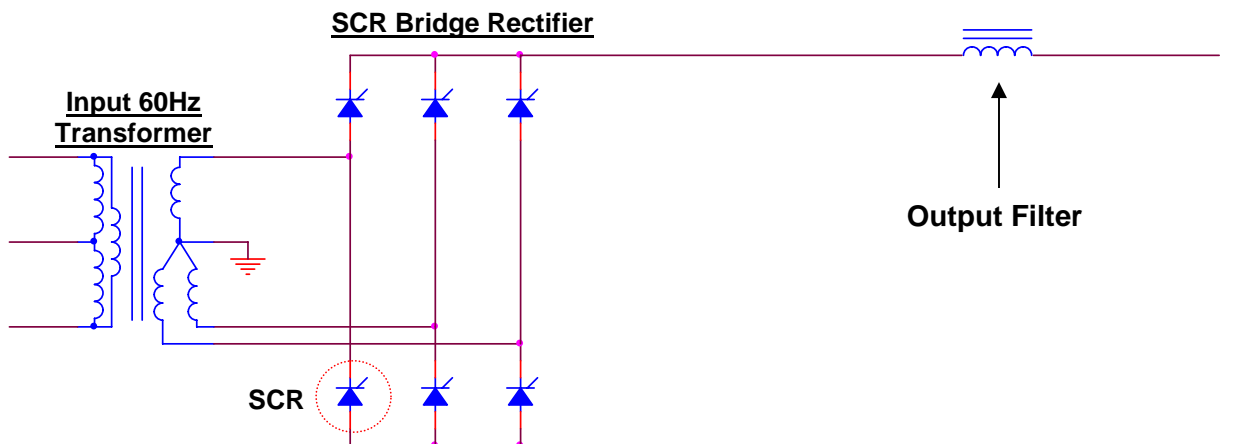

**Fig. 2: SCR Battery Charger as Compared to a Low Frequency Isolated IGBT Charger**

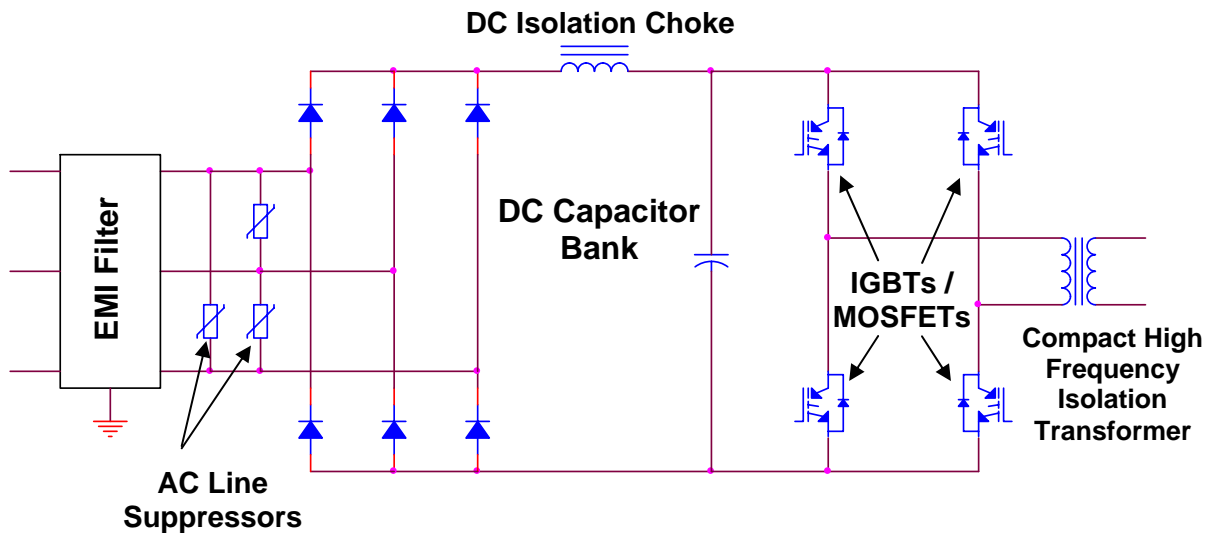

**Fig. 3: High Frequency Isolated (Off-Line) IGBT Battery Charger**