

WARRANTED AMP HOURS: A NEW WAY TO OFFER AND MANAGE BATTERY WARRANTIES FOR INDUSTRIAL BATTERIES

Nasser Kutkut

PowerDesigners, LLC
931 E. Main Street Suite 4
Madison, WI 53703, USA
T: +1.608.231.0450 F: +1.608.231.9979
kutkut@powerdesigners.com

ABSTRACT

This paper proposes a new scheme to offer battery warranties based on the total discharge amp-hours over the battery lifetime. The new *Warranted Amp-Hour* feature can be managed by equipping the batteries with advanced battery monitoring systems that are capable of monitoring battery activity including amp-hour usage over the battery life. With *Warranted Amp-Hours*, battery OEMs and end users can better track and manage battery warranties, plan maintenance schedules, and greatly increase battery service life. An activity based battery monitor will also provide end users and OEMs with a wealth of data over the life of their batteries.

INTRODUCTION

Almost all industrial battery OEMs offer battery warranties based on time with the average warranty being five years. This has been the practice in an industry that has been dominated by conventional use of these batteries, namely, conventional charging and one shift per day of use for motive applications. Yet, most of these warranties include restrictions on battery usage and depth of discharge as well as requirements for record keeping and proper maintenance making warranty claims past the first few years almost impossible. Examples of typical restrictions are:

- Limiting battery usage to one cycle of discharge and recharge (cycle) per day
- A maximum of 300 cycles per calendar year
- Maximum depth of discharged is 80 percent of the rated six hour capacity
- Maintaining records of operation and conditions over the warranty period
- Performing some sort of regular maintenance including capacity tests

Managing such warranties is not straightforward, both for OEMs and end users, especially in the absence of any relevant historical data on the performance and use of these batteries. In addition, with the advent of fast charging techniques and higher utility

of industrial batteries, battery OEMs are less tempted to extend their standard warranties to include these new applications. One approach is to reduce the warranty period for applications employing fast charging to accommodate the higher usage of these batteries. Yet, deciding on the warranty period is a challenge especially if mixed mode operation and utility is utilized. As a result, end users are left with the dilemma of deciding whether to risk adopting new fast charge technologies in the absence of solid backing by OEMs. Add to that some misconceptions about the impact of fast charging on battery life where many have equated the reduction in battery life cycle due to the increased utility with a reduction in battery life span, although the total energy throughput is the same as with conventional charging.

THE WARRANTED AMP-HOURS WARRANTY

The above challenges can be alleviated if battery warranties are offered based on the total amp-hour usage (throughput) of the battery. Under normal operation, the normal 'end of life' condition of a battery occurs when the capacity of one or more cells drop significantly (below 80%) due to the positive plate grid having oxidized (corroded). If the battery is properly maintained, one can establish a direct relationship between the total energy extracted from the battery over its life and the end of life, i.e., the battery will reach end of life after the rated total-amp hour of discharge has been extracted. This gives rise to offering warranties based on amp-hour throughput through the battery. Instead of offering time-based warranties, OEMs can extend *Warranted Amp-Hour* figures to end users regardless of their application or battery usage.

Estimating the total amp-hours of discharge that a properly maintained battery would supply over its lifetime is a simple and straightforward process and incorporates typical assumptions. For example, consider a typical 500 amp-hour battery used in a typical motive power application. Assuming that the battery is used one shift per day, six days a week, and is discharged down to a maximum of 80% depth of discharge (DOD). With proper maintenance and charging, this battery would last on average for 5 years, based on battery OEM warranties. The total lifetime discharge amp-hours over the life of the battery can be estimated using:

$$\text{Lifetime Discharge Amp - Hours} = \text{DOD} \times \text{Rated Ahrs} \times \text{Utility} \times 52\text{wks} \times Y \quad (1)$$

where:

- DOD: Depth of discharge per cycle
- Utility: Battery usage in days / week
- Y: Average replacement life in years

For our example,

$$\text{Lifetime Discharge Amp - Hours} = 80\% \times 500 \text{ Ahrs} \times 6 \text{ Days} \times 52\text{wks} \times 5\text{yrs}$$

$$\text{Lifetime Discharge Amp - Hours} = 624,000 \text{ Ahrs}$$

In general, the average total lifetime discharge amp-hours of discharge for a C-rated amp-hour battery with the above assumptions is given by:

$$\text{Lifetime Discharge Amp - Hours} = 1248 \times \text{Ahrs} \quad (2)$$

From (2), a typical manufacturer can develop a simple formula to offer warranties, simply given by multiplying the rated amp-hours of the battery with a constant. Using the above assumptions, the constant is 1248.

Although presently no battery manufacturer offer warranties based on amp-hour throughput, most indirectly do exactly that. In fact, since most manufacturers offer a typical warranty period of 5 years and restrict battery utility to 300 cycles per year (or 1500 cycles over the battery life) with a maximum of 80% DOD, this translates into a *Warranted Amp-Hours* of:

$$\begin{aligned} \text{Warranted Amp - Hours} &= 5 \times 300 \times 80\% \times \\ \text{Warranted Amp - Hours} &= 1200 \times \text{Ahrs} \end{aligned} \quad (4)$$

which is consistent with the above assumptions (2).

With the *Warranted Amp-Hours* plan, battery OEMs would not need to verify whether the batteries are used with conventional charging / utility versus rapid charging / higher utility and will have a simple way to manage and track these warranties. In addition, a universal warranty scheme is offered making it simpler for users to understand and accept.

EXTRACTING WARRANTED AMP-HOURS FROM LIFE CYCLE DATA

The notion of *Warranted Amp-Hours* has already been embedded in the data that battery OEMs supply, namely the battery life cycle versus the depth of discharge or the retained capacity for both motive and stationary batteries. For example, referring to a typical life cycle curve versus % DOD, as shown in Figure 1, one can translate the data easily to a normalized life-time amp-hours data by simply multiplying the number of cycles by the % depth of discharge.

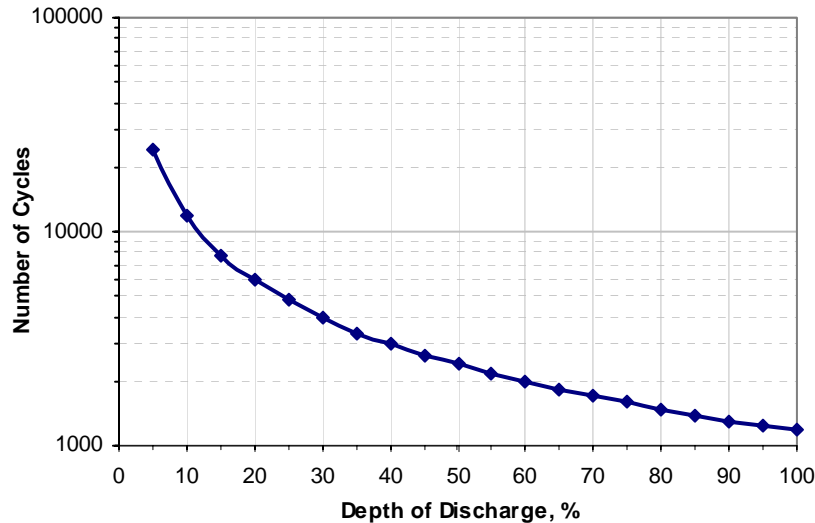

Figure 1: Number of Cycles vs. % Depth of Discharge per Cycle

The resulting data is plotted in Figure 2. It can be clearly seen from Figure 2 that normalized life-time amp-hours (throughput) varies within a narrow band with a mean of 1195 and less than 6% variation around the mean. As a result, one would contend that the battery OEM for that specific battery can offer a Warranted Amp-Hours of $1150 \times C$ with C being the rated amp-hour rating of the battery.

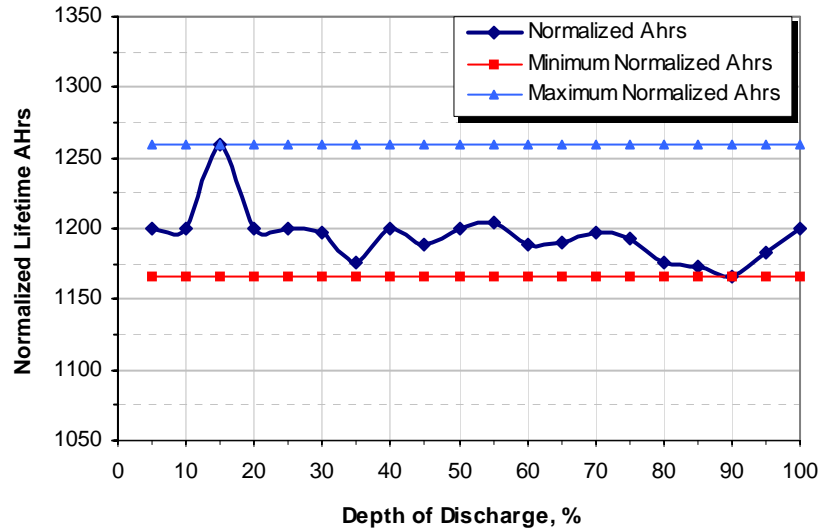

Figure 2: Normalized Life Time Amp-Hours

BATTERY MONITORING REQUIREMENTS

In order for battery OEMs, as well as users, to offer and manage battery warranties based on the total lifetime discharge amp-hours, advanced battery monitoring systems are needed. The minimum requirements for such a battery-monitoring device include:

1. Ability to track and save the total lifetime discharge amp-hours, which gives rise to a *Discharge Amp-Hour Meter*.
2. Ability to track and save charge and discharge amp-hours for all charge and discharge cycles, respectively. This will allow OEMs and users to verify the depth of discharge over all discharge cycles as well ensure proper charging of the battery as well as provide operation and use records for the batteries.
3. Ability to track battery temperature over charge and discharge cycles. Since temperature greatly impacts battery life as it affects the grid corrosion rates, battery OEMs may have to adjust their warranties if higher operating temperatures are encountered.
4. Ability to track and save charge and discharge hours as well as the hours of open circuit. This will help determine the battery utility, which is used in the warrant formula.

5. Maximum charge voltage and minimum discharge voltage, which allows OEMs and users to identify overcharge / discharge events.
6. Ability to save battery ID, installation time, and real time for tracking and managing warranties properly.
7. Permanently installed on the battery.
8. Ease of use in terms of data downloading and interpretation.
9. Cost effective.

Given the above requirements, and since the total amp-hours of charge or discharge need to be recorded, a current sensing device must be used. Without one, any battery-monitoring device will be less effective.

An activity based battery data logger that meets the above requirements is needed, and example of which is the PowerTrac SP that has been recently introduced by PowerDesigners. The patented battery monitoring system consists of a current sensing device, such as a current shunt, and monitor, which incorporates the analog and digital circuitry as well as the on-board memory (Fig. 3). The monitor is equipped with an IR port for wireless communication via an IrDA enabled device. The new PowerTrac battery monitoring device tracks all charge, discharge, and open circuit events over the lifetime of the battery and saves all critical data on board. Data download can be easily achieved via a Palm type device (Palm Pilot) using the on board IR port. Advanced GUI user interface allow for advanced data processing and interpretation.

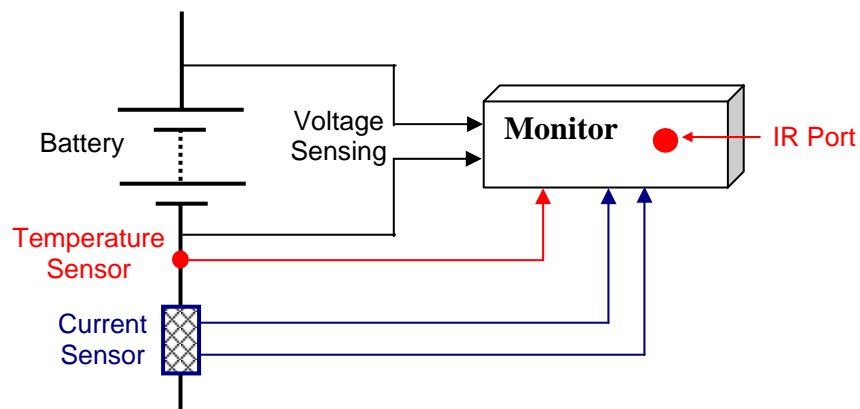

Fig. 3: Block Diagram of the New Activity Based Data Logging System

Battery OEMs, as well as users, can program the various parameters upon installation. This includes the proposed *Warranted Amp-Hour* feature as shown in Figure 4. This is a password-protected feature to prevent misuse of corruption of data. OEMs and users can download and view the stored data for tracking and maintenance purposes.

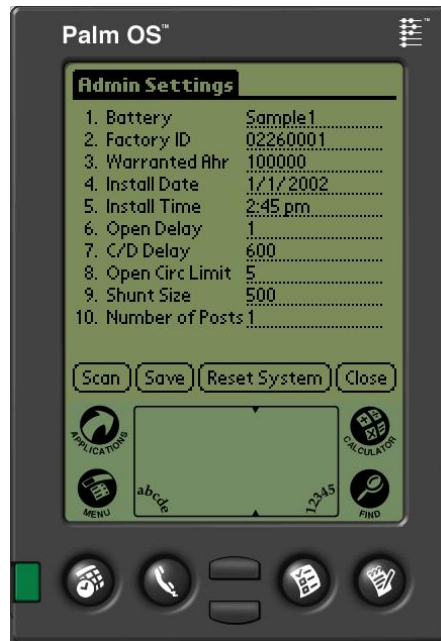

Fig. 4: Typical Palm screen showing installation data as well as programmed *Warranted Amp-Hours*

CONSLUSION

Warranted Amp-Hours is an effective and simple technique to offer and manage battery warranties. Unlike time based warranty plans, the *Warranted Amp-Hour* approach truly reflects the actual energy throughput of the battery regardless of the battery utility, i.e. charge and discharge rate. The proposed *Warranted Amp-Hour* warranty plan can be enforced and managed by equipping the battery with intelligent activity based battery-monitoring systems that can track the amp-hour usage as well as provide operation and usage records over the battery warranty period.

References

- 1- US Patent No. 6,549,014 B1: Battery Monitoring Method and Apparatus, by Nasser Kutkut and D. Brobst.
- 2- Mick McGill, Maintaining Your Motive Power Investment: Battery Maintenance Tips to Increase Return on Investment, Industrial, Utility Vehicle & Mobile Equipment Magazine - March/April 2002.
- 3- *TUDO Standby Batteries*, <http://www.tudor.se/eng/standby/pdf/1-generalinfo.pdf>.